

MINIDOZER M-27

TECHNICAL SPECIFICATIONS

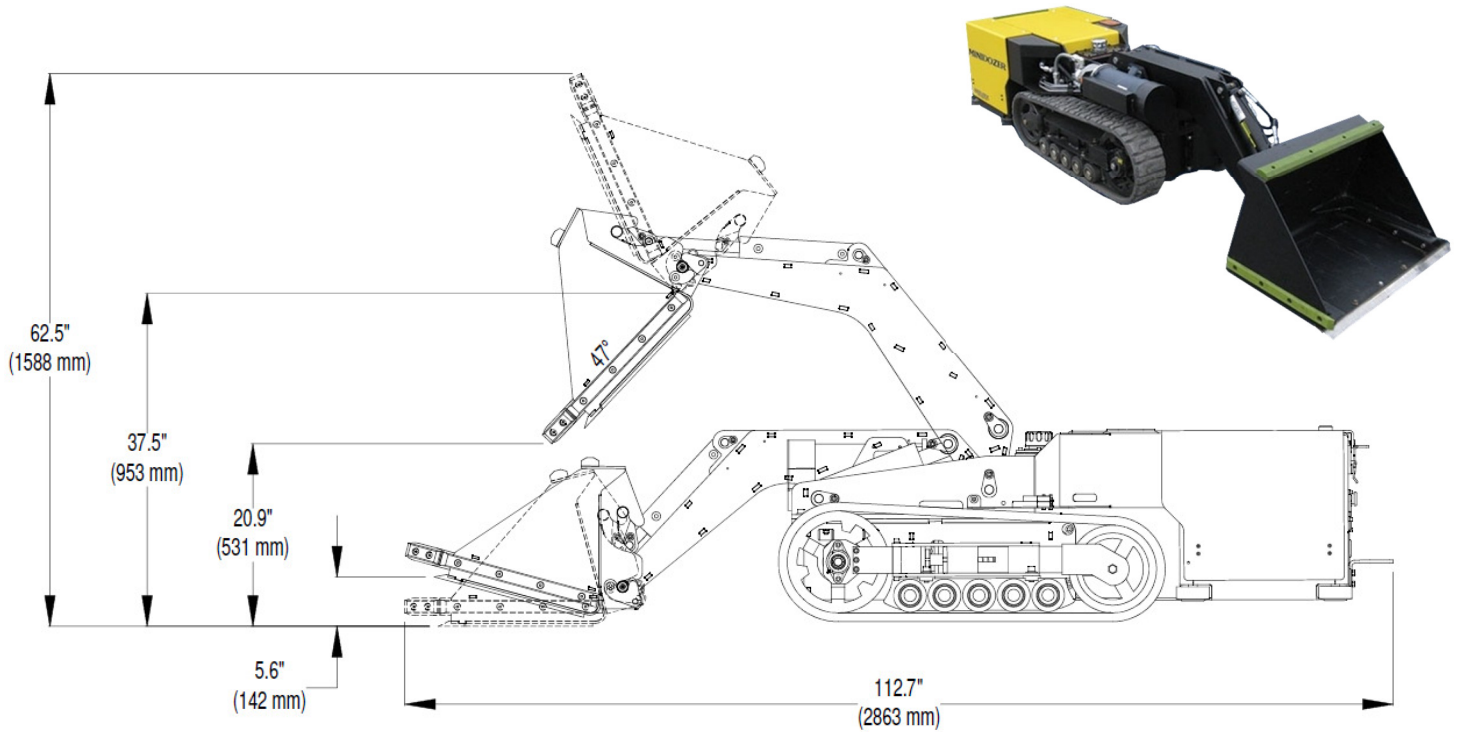

PHYSICAL CHARACTERISTICS		
Frame	Steel	
Cabinet	Aluminum	
Length	112 ³ / ₄ in	2863 mm
Width	27 ³ / ₄ in	705 mm
Height (frame)	22 ⁵ / ₁₆ in	567 mm
Height (bucket to maximum)	62 ¹ / ₂ in	1590 mm
Clearance Under Bucket (to maximum height)	37 ¹ / ₂ in	950 mm
Weight	2200 lb	998 kg
Turning diameter	163 in	4140 mm
Lifting Capacity	642 lb	241 kg
Bucket Capacity	0.096 yd ³	0.073 m ³
Maximum speed (flat surface)	66 ft/min	20.1 m/min

POWER	
Motor power	2 HP (x2)
Hydraulic motor power (bucket)	2 HP (x1)
Gearbox ratio	75:1 (x2)
POWER FEATURES	
Batteries Amperage/Voltage	435 Amp at 6 Volts (x4)
Charger	AC-DC external (x1)
Battery Pack Amperage	435 Amp
Operating Voltage	24 VDC
Continuous Run-Time	8 hours approx. (no load, flat surface)
Battery Recharging Time	12 hours approx.
Control	Wireless (standard)

The information contained in this document is subject to change without notice.